

# Lifair

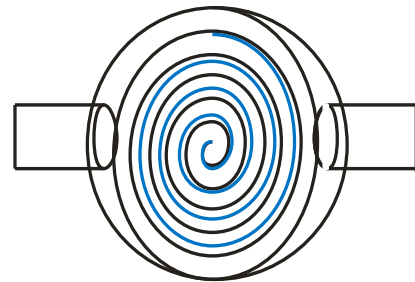
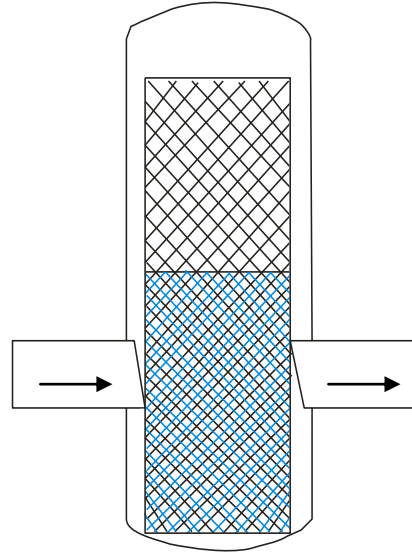
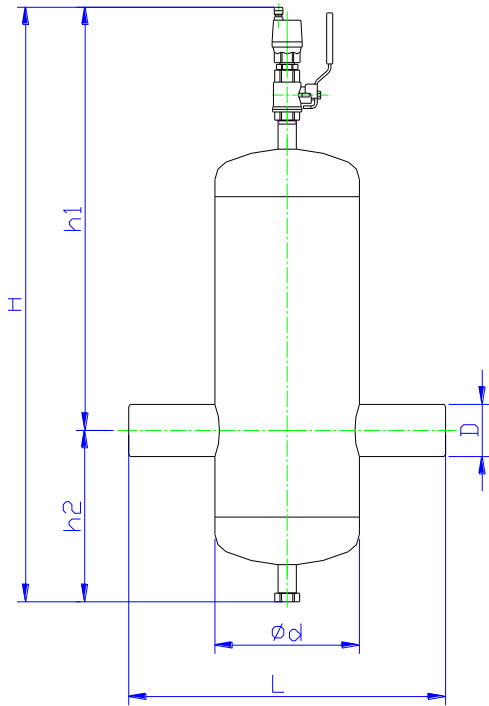

DIMENSIONS  
 OPERATING TEMPERATURE AREA  
 PRESURE CLASS  
 TEST PRESSURE  
 FILTER  
 BODY  
 WELDING  
 SEALING

DN25-250  
 0-120°C

PN10

PN16  
 AISI 304  
 St35.8 or St37.0  
 St35.8 or St37.0  
 COPPER

DN	25	32	40	50	65	80	100	125	150	200	250
Type W	200025	200032	200040	200050	200065	200080	200100	200125	200150	200200	200250
Type F	201025	201032	201040	201050	201065	201080	201100	201125	201150	201200	201250
D(mm)	33,7x2,6	42,4x2,6	48,3x2,6	60,3x2,9	76,1x2,9	88,9x3,2	114,3x3,6	139x4	168,3x4,5	219,1x6,3	273x6,3
H	562	562	562	704	704	734	734	900	900	1300	1300
Ød	114,3	114,3	114,3	168,3	168,3	219,1	219,1	324	324	324	508
L	315	315	315	369	369	417	417	500	500	500	750
F	395	395	395	459	459	517	517	610	610	610	850
h1	232	232	232	360	360	376	376	550	550	900	900
h2	180	180	180	194	194	208	208	300	300	350	350
weight kg W	5	5	5	14,5	14,5	25,0	25,0	45	46	60	170
weight kg F	7	8	8	20	21	32	34	57	61	82	200
Volume L	3,2	3,2	3,3	8,9	9,0	19,0	19,2	65	65	80	200

